

# STRUCTURAL ANALYSIS AND DESIGN OF STEEL CONNECTIONS USING CBFEM METHOD

Lubomír Šabatka<sup>\*</sup>, Jaromír Kabeláč<sup>\*\*</sup>,  
Drahošlav Kolaja<sup>\*</sup>, Martin Pospíšil<sup>\*</sup>

<sup>\*</sup>IDEA RS s.r.o.  
U Vodárny 3032/2a, 616 00 Brno, Czech Republic  
e-mail: [sabatka@idea-rs.com](mailto:sabatka@idea-rs.com), website: [www.idea-rs.com](http://www.idea-rs.com)

**Keywords:** Steel structures, structural connections, finite element model, component model, analytical model, design model

**Abstract.** *This paper introduces component based finite element model (CBFEM) which is a new method to analyse and design connections of steel structures. Design focused component model (CM) is compared to finite elements models (FEM). Procedure for composition of a model based on usual production process is used in CBFEM. Its results are compared to those obtained by component method for portal frame eaves moment connection. Design of moment resistant column base is demonstrated by a case loaded by two directional bending moments and normal force. Interaction of several connections in one complex joint is explained in the last example.*

## 1 INTRODUCTION

This article further develops the paper published during Steel, Space and Composite Structures Conference, held in Prague in May 2014: Šabatka L., Wald F., Kabeláč J., Gödrich L., Navrátil J., Component based finite element model of structural connections. Described method was created under R&D project MERLION supported by Technology Agency of the Czech Republic (project No. TA02010159).

## 2 COMPONENT AND FINITE ELEMENT MODELS OF CONNECTIONS

Component model of connections builds up on standard procedures of evaluation of internal forces in connections and their checking. Zoetemeijer [1] was the first who equipped this model with prediction of stiffness and deformation capacity. The elastic stiffness was improved in the work of Steenhuis, see [2]. Basic description of components behaviour in major structural steel connections was used by Jaspart for beam to column connections [3] and by Wald for column bases [4]. The model was generalised by da Silva [5]. Method implemented in the current European structural standard for steel and composite connections see [6] and [7] and can be applied in majority of software for structural steel used in Europe. Procedure starts with decomposition of a joint to components, see Fig. 1, followed by their description in terms of normal/shear force deformation behaviour. After that, components are grouped to examine joint moment-rotational behaviour and

---

<sup>\*\*</sup>Hypatia Solutions s.r.o

classification/ representation in a spring/shear model and application in global analyses. The components in Fig. 1 represent: 1 – column web in shear, 2 – column web in compression, 3 – beam flange and web in compression, 4 - column flange in bending, 5 – bolts in tension, 6 – end plate in bending and 7 – column web in tension. Advantage of the component model is integration of current experimental and analytical knowledge of connections components behaviour (bolts, welds and plates). This provides very accurate prediction of behaviour in elastic and ultimate level of loading. Verification of the model is possible using simplified calculation. Disadvantage of component model is that experimental evaluation of internal forces distribution can be done only for limited number of joint configurations. In In temporary scientific papers, description of atypical components is either not present or has low validity and description of background materials. Models of hollow section connections are described in Ch. 7 of EN1993-1-8 [6] by curve fitting procedures; their compatibility with component model is unreliable. The CM's are rather complex for hand calculation, resulting in a need to use of tools/design tables.

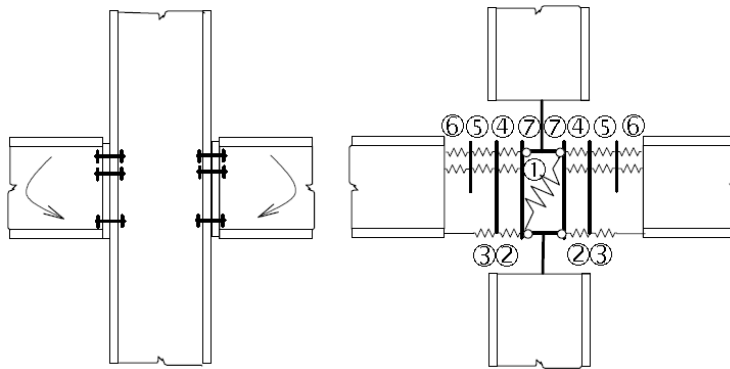

Figure 1: Component model of symmetrical beam to column connection with end plates

Finite element models (FEM) for connections are used from 70s of last century and they are research-oriented. Their ability to express real behavior of connections is making them a valid alternative to testing – standard and expensive source of knowledge of connection's behavior. Native process of computer based design is validation and verification (VaV) of models, see [8]. Application of VaV to steel connections design is limited to a few published benchmark studies, see [9]. Comparison of VaV to different engineering application is still to be done [10]. Material model for FEM uses true stress stress-strain diagram, see Fig. 2. Strain is recommended to be limited to 5%, see cl. C.8(1) EN1993-1-5, [11]. Implementation of safety into advanced design models under ultimate limit state design is summarised in cl. C.9(2) EN1993-1-5 [11]. Standard procedure with partial safety factors for material/connections may be applied. More advanced and accurate solution, which takes into consideration the accuracy of model and material separately, gives more accurate and economical solution of structural connections.

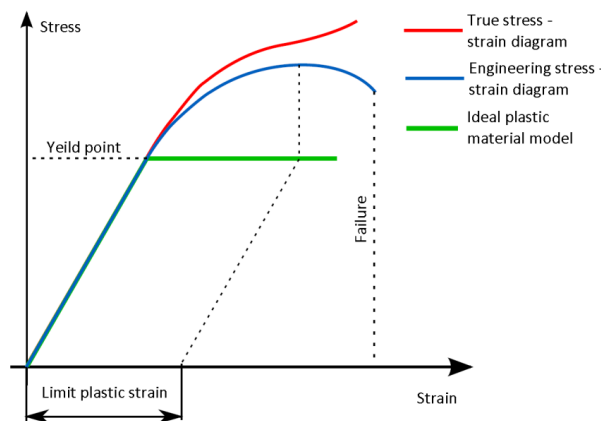

Figure 2: Material models of steel for research and design oriented methods

### 3 COMPOSITION OF CBFEM MODEL

CBFEM is based on decomposition of the whole joint into separated components – steel plates, welds, bolts and anchors, concrete block. Each component has its own analysis model:

- 2D plate/wall finite elements for steel plates of stubs of hot/cold formed cross section
- Force interpolation constrains for welds
- Nonlinear springs for bolts and anchors
- Contact elements between plates in connections
- Winkler/Pasternak subsoil for concrete blocks.

First step in creating of the model is preparation of its geometry. Structural engineer creates the structural joint by applying manufacturing operations using these components, see Fig. 3. Meshing of the components is automatically done by software.

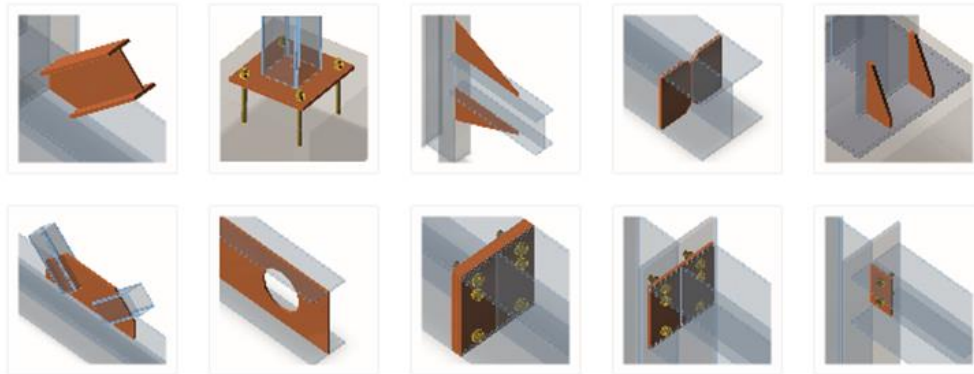

Figure 3: Manufacturing operations applicable to the structural joint

The plates connected by welds are modelled separately. They are connected by weld component only, which is characterised by weld in plane and out of plane tensile stiffness and resistance. The bolts are modelled as two fans of interpolation links with its tensile and shear trilinear stiffness and adequate resistance. Slender compressed plates are checked for local buckling. Possible post buckling behaviour of class 4 sections is introduced by effective stress of each compressed plate.

## 4 CASE STUDIES

### 4.1 Welded portal frame eaves moment connection

The CBFEM model of the portal frame eaves moment connection with parallel stiffeners was verified by the CM. Results show a good agreement between two models. After that, sensitivity study was performed. Beam IPE cross-section size is variable parameter shown on horizontal axis, see Fig. 4. Column HEB 260 was considered. The resistance shown on vertical axis represents force couple of bending moment in plane  $M_y$  and vertical shear force  $V_z$  for which the ultimate limit state was reached. It is assumed, that bending moment and shear force values are equal. Resistance of the connection was governed by two components, column panel in shear and beam flange in compression. Comparison of critical component for both CBFEM and CM models was made. The same component was critical in both models for all parameters. Results of both models are very similar, differences in resistance are up to 7% and only in uncommon cases, e.g. column HEB 260,

beam IPE 500. To cover the CBFEM model uncertainty, factor  $\alpha_1$  will be determined according to sensitivity studies [11].

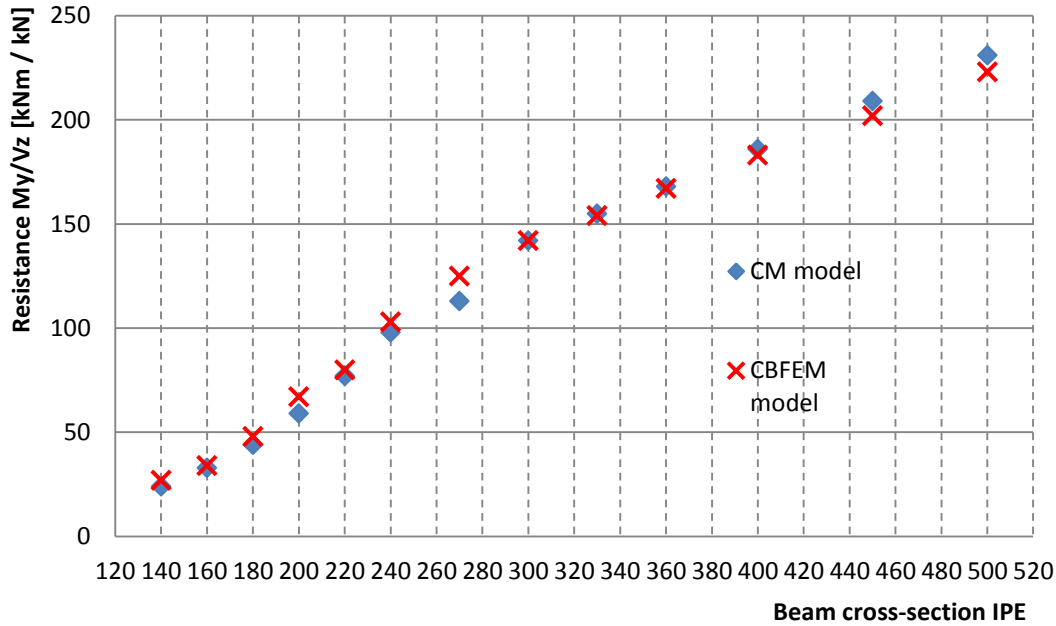

Figure 4: Sensitivity study, Column HEB 260, variable parameter is beam cross-section size

Study of the moment connection in the corner of portal frame is visualised on Fig. 5. Design resistance and distribution of internal stresses are shown for three types of a joint - with unstiffened beam web, parallel stiffeners and inclined stiffener in compressed part of column web. These models were verified against CM with good accuracy. However, reaching this results using CM to the joint with inclined stiffener is very time consuming and with limited optimisation features.

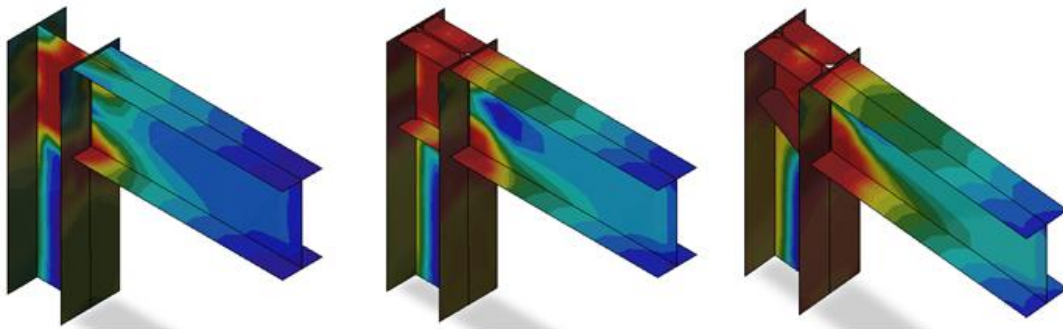

Figure 5: Influence of the shear stiffener to eaves moment connection; from left 46,5 KNm; 61,3 kNm; and 73,0 kNm

#### 4.2 Column base with base plate

Nowadays, tools using CM supports column base with base plate design with or without stiffeners. The example is calculated with loading in two perpendicular principal directions; in case of loading by bending moments in general plane the result is obtained by interaction, see cl. EN 1993-1-8. The accuracy of interaction is limited to linear behaviour and may result in 30 % overestimation. The CBFEM model was validated with good accuracy against experiments both from literature and carried out specifically for this purpose by authors. The verification of cases loaded by moment in

major/minor axes performed against CM gives good results. The CBFEM model, directly performing calculation under general loading, allows engineers to optimise stiffeners and plate.

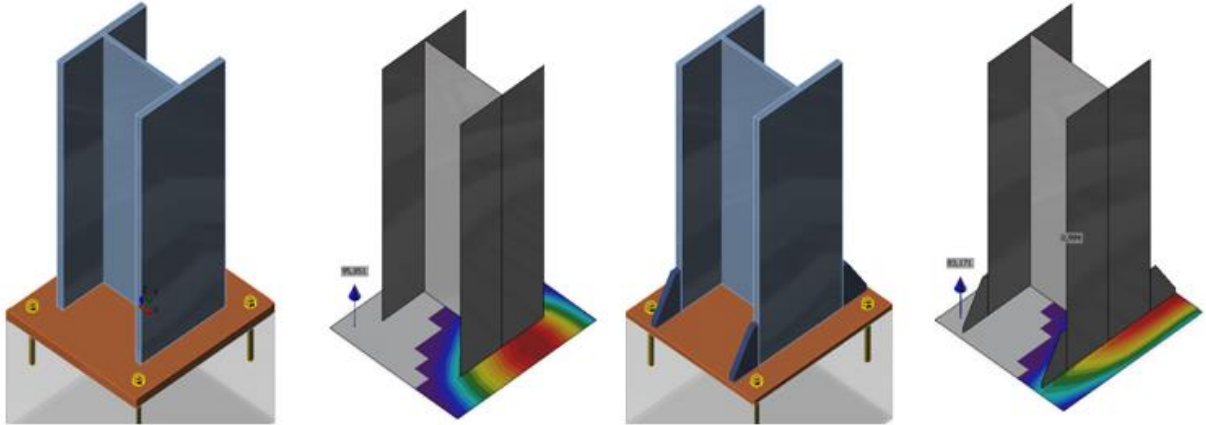

Figure 6: Stress in concrete under unstiffened base plate 35 mm (left) and stiffened base plate 22 mm loaded by general moment (right)

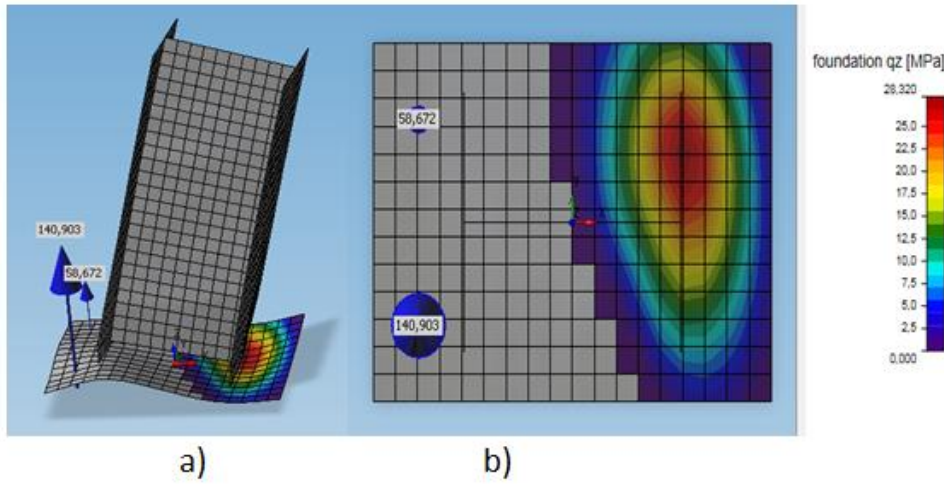

Figure 7: Base plate loaded by general moment  
a) deformed shape, b) stress in contact area

## 5 ANALYSIS OF A COMPLEX STEEL JOINT

Interaction of several connections in one joint is very hard to solve using CM. Analytical CM needs to be created manually for every type of the joint. On the other hand, there are no limitations for typology and number of members used in CBFEM method.

General effectiveness of the method is shown on an example of a frame joint. There are following members in the joint: connection on bolted end-plate with ribs, connection on shifted end-plate with stiffener, connection of skewed beam on short end-plate, rectangular hole in the web and several stiffeners. All these members can be solved separately by CM but the overall capacity of the joint is also defined by their interactions – true capacity of a given connection cannot be defined without analysis of a connection located next to it.

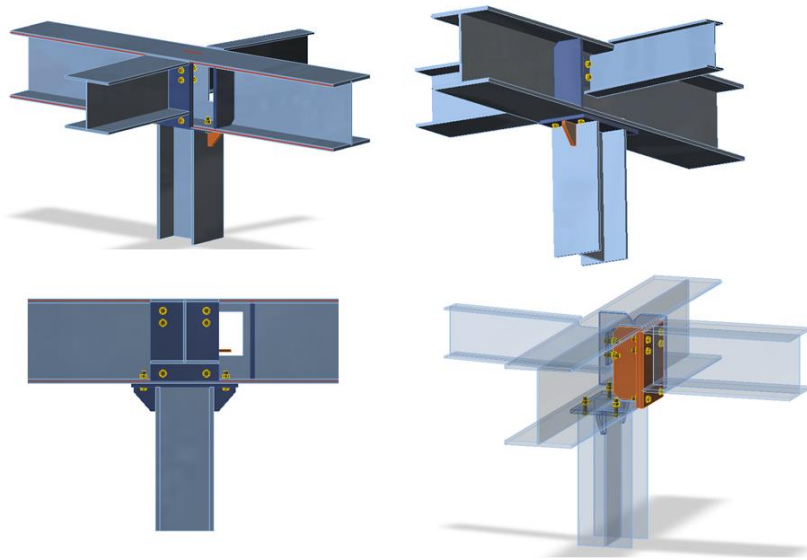

Figure 7: Complex frame joint – interaction of more connections

Presentation of calculated results is very important for clear understanding of CBFEM method. Fig. 8 shows stresses in steel plates and developing of plastic zones in different parts of the joint.

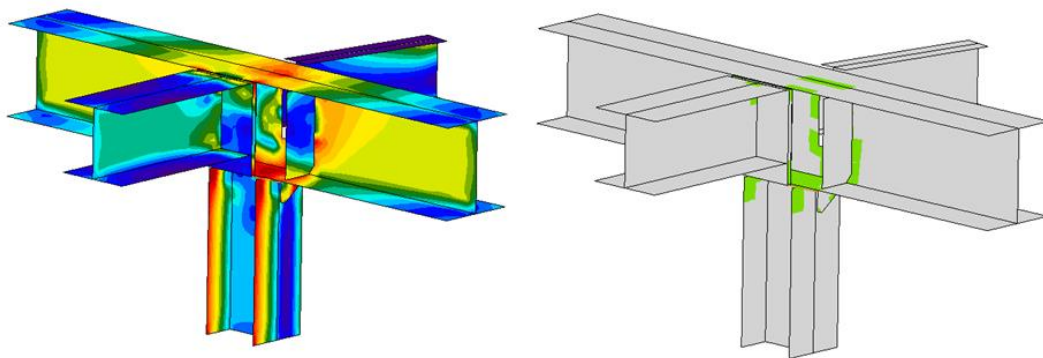

Figure 8: Stresses and plastic zones in complex steel joint

## 6 CONCLUSIONS

Commonly used Component Method (CM) is laborious for hand calculation and its application by design tools in practice is limited to certain types of connections and their loading. Use of computer based design of structural connections by RSFEM is limited to proper validation and verification procedures.

Component Based Finite Element Model (CBFEM) was developed. Its validation using both published and undisclosed experiments with open and hollow section connections and column bases is under progress. Based on configurations verified by published results, CBFEM provides more variability in geometry and loading than simplified procedures in current CM.

## REFERENCES

- [1] Zoetemeijer, P.: *Summary of the Researches on Bolted Beam-to-Column Connections*. Report 6-85-7, University of Technology, Delft 1985.
- [2] Steenhuis M., Gresnigt N., Weynand K. : *Pre-Design of Semi-Rigid Joints li Steel Frames*, Proceedings of the Second State of the Art Workshop on Semi-Rigid Behaviour of Civil Engineering Structural Connections, COST C1, Prague, 1994, 131-140.
- [3] Jaspart J.P. : Design of structural joints in building frames, *Prog. Struct. Engng Mater.*, 4 (2002) 18–34.
- [4] Wald F., Sokol Z., Steenhuis M. and Jaspart, J.P. : Component Method for Steel Column Bases, *Heron* 53 (2008) 3-20.
- [5] Da Silva Simoes L. : Towards a consistent design approach for steel joints under generalized loading, *Journal of Constructional Steel Research*, 64, 1059-1075, 2008.
- [6] EN1993-1-8, Eurocode 3, Design of steel structures, Part 1-8, *Design of joints*, CEN, Brussels, 2006.
- [7] EN1994-1-1, Eurocode 4, Design of composite steel and concrete structures, Part 1-1, *General rules and rules for buildings*, CEN, 2010.
- [8] Wald F., Kwasniewski L., Gödrich L., Kurejková M. : *Validation and Verification Procedures for Connection Design in Steel Structures*, Proceedings Steel, Space and Composite Structures, in printing, Prague, 2014.
- [9] Bursi O. S., Jaspart J. P. : Benchmarks for Finite Element Modelling of Bolted Steel Connections, *Journal of Constructional Steel Research*, 43 (1-3), 1997, 17-42.
- [10] Virdi K. S. et al : *Numerical Simulation of Semi.Rigid Connections by the Finite Element Method*, Report of Working Group 6 Numerical, Simulation COST C1, Brussels Luxembourg, 1999.
- [11] EN 1993-1-5, Eurocode 3: Design of steel structures - Part 1-5: *Plated Structural Elements*, CEN, Brussels, 2007.
- [12] Sabatka L., Wald F., Kabeláč J., Gödrich L., Navrátil J.: Component based finite element model of structural connections, Steel, Space and Composite Structures, Praque, 2014. Available at: <http://www.idea-rs.com/lectures-and-articles/connection-research-paper/>
- [13] IDEA RS: Product documentation, [www.idea-rs.com](http://www.idea-rs.com), 2014